



ΙΜΡΑΓΙΑ™



Located in the heart of Milan district, a fashion landmark known around the world, creativity and a flair for design is a part of everything Impatia does. Uniting the traditions of Italian design, art, and craftsmanship, it produces bespoke, luxury gaming tables that are sure to become a talking point in your home. At its core, Impatia embodies the principle of daring, distinct design that is destined to become a true classic.

MASTERPIECES OF ITALIAN ARTISTRY

Whether it's the design, the craftsmanship, or the materials used, Impatia always draws upon the highest quality Italian traditions and innovations, to create something that is at once classic and modern. It collaborates with talented artisans from across Italy to bring you the very best, a product which transcends mere design to become a one-of-a-kind classic that only Italy can produce.

Innovative, sophisticated design and production methods are behind every one of our products, so that you can be sure of a gaming table the likes of which you won't find anywhere else.

PHILOSOPHY and MISSION

Impatia is the new BD Collection, its 2.0, a brand that goes beyond the concepts of B2B and B2C aiming towards a new dimension, an empathic one, the H2H - Human to Human.

IMPATIA's design ethic is one which does not accept limitations, and instead strives to create extraordinary products that are both functional and beautiful. Not only does Impatia offer one of a kind designs, but it also takes care of its customers' every wish, to ensure they receive a piece which perfectly matches their spirit. By putting empathy at the center of what it does, Impatia is able to give customers an experience which is as unique as our designs.

IMPATIA'S SOUL

Gregg Brodarick is the founder and creative director of IMPATIA. For the past 25 years, he has been splitting his time between Italy and the U.S.A., an experience which laid the foundation of the company's designs which seek to bring together the functionality of the modern world with the sophistication and splendor of the old world. Having gained both a bachelor's and master's degree in architecture, his keen eye for detail and pursuit of purity and beauty in design are reflected in the core design ethic of IMPATIA itself.

CALMA E GESSO

IMPATIA's first collection, Calma e Gesso, has been designed by the Torino based company Adriano Design. Formed of brothers Davide and Gabriele Adriano, their work has been displayed in some of the most distinguished museums, including the Triennale Design Museum and the Chicago Atheneum. They have received numerous international awards, including the Compasso d'Oro ADI 2014. The Calma e Gesso Collection perfectly sums up mission of creating pieces which refuse to play by the rules.

FILOTTO



LAUNCHING THE BRAND IS THE CLASSIC GAME OF BILLIARDS

Launching the brand is the classic game of billiards, an emblem of leisure originating from the palaces of the bourgeois which has since become a popular sport across the generations. The first challenge of Impatia has been in recreating a product with such a long history but so little evolution.

The magic lies in having realized a thin, steel frame, which is both adjustable, divisible, and supports the solid slate game surface, as well as the crystal structure that characterizes this new design. The unique feeling of seeing a 600kg billiard table 'float' on four legs is second only to the pleasure of playing on this Italian masterpiece.

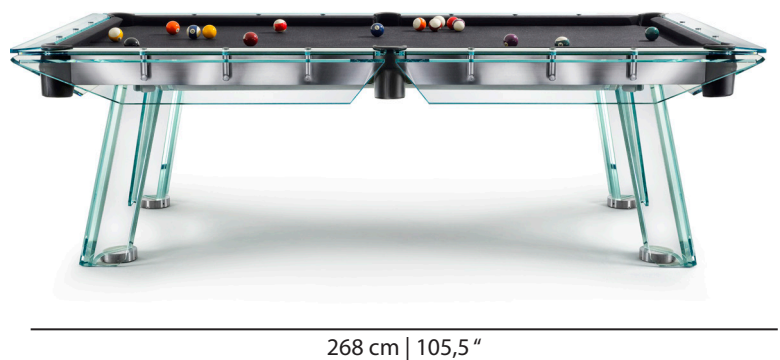

- ◇ Crystal glass case and table legs
- ◇ Stainless frame and components
- ◇ Italian slate playing field

◆◆◆◆◆ Simonis wool clothes available in 25 different colors



FILOTTO WOOD



NEW LIMITED
EDITION 2015

50 SIGNED UNITS

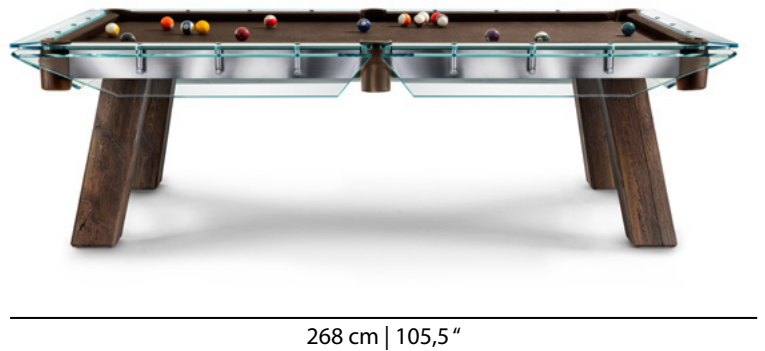

MARBEL CUE RACK

ARTISAN
PRODUCTION,
MODERN STYLE,
ITALIAN QUALITY

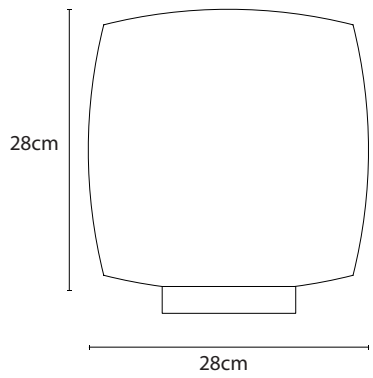
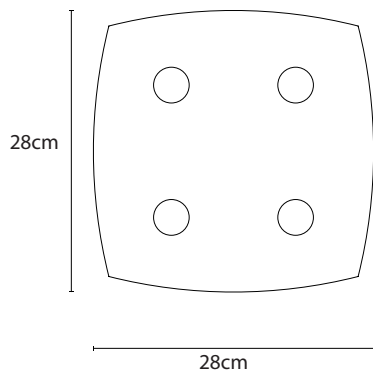

PERFECT DUET OF
TECHNOLOGY AND
BEAUTY



◆◆◇ Marble cue holder available in 3 different colors

LUNGOLINEA



DEMONSTRATING
THE INGENUITY OF
ITALIAN DESIGN AND
CRAFTSMANSHIP

Giving a new guise to a game born in the eighteenth century is an incredible challenge. Impatia's designers already knew what they were undertaking when they decided to redesign the ping-pong table and transform it into a superlative object of design: "Lungolinea".

The idea of playing on a transparent games table seems unimaginable, but thanks to a series of spectacular inventions it is now possible for even the most competitive professional players to enjoy a game of ping-pong on a table made of glass. With Lungolinea, Impatia has a new magic with which to astonish the world of luxury.

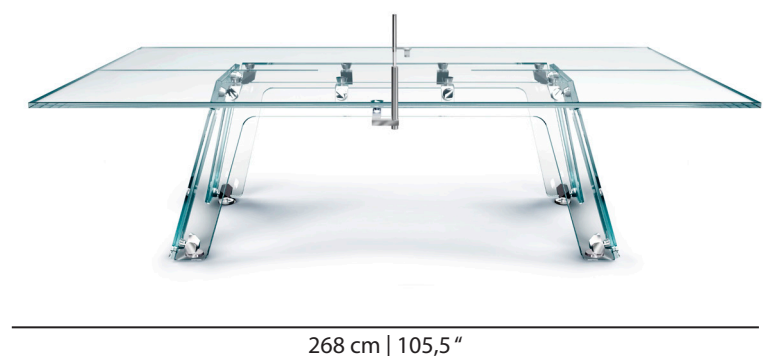
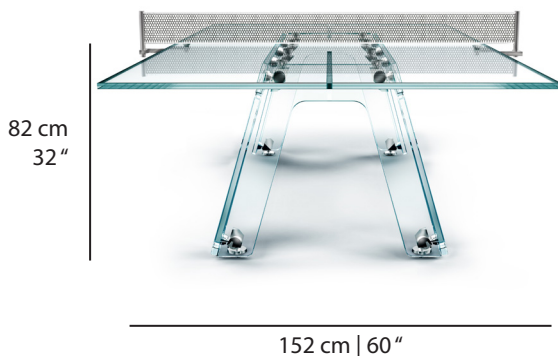

- ◇ Crystal glass structure
- ◇ Stainless frame and components
- ◇ Custom table tennis net

IN-THE-ZONE

In positive psychology, the concept of flow, also known as the zone, is the mental state of operation in which a person performing an activity is fully immersed in a feeling of energized focus, full involvement, and enjoyment in the process of the activity.

A poker player is “in the zone” when he is able to merge with the game; when he’s completely unaware of what’s going on around him as he is so extremely into what’s going on in front of his face; when he is totally concentrated on the playing field dynamics and when he is able to read into the other players’ strategies and convert into success of his own – a concentration level so high to be reached by some chosen ones only.

DESIGNER portrait

Architect and designer Enrico Azzimonti founded his own studio in 1994 in an earlier ‘900 factory that looks onto Sempione, the nineteenth-century Napoleonic road that links Milan with Paris.

Driven by a passion for design, his aim is project innovation and product perfection. He works together with firms to promote the Italian industrial design and make it a key point for international success.

He manages small products as well as big products with enthusiasm, bringing design culture to every project.

He designed the Unootto Poker Table together with IMPATIA combining the focus on technique with the sophistication of artisanal manufacture, aiming to give birth to a luxury icon object.

UNOOTTO



DESIGN THAT IS
DESTINED TO
BECOME A TRUE
CLASSIC

Inspired by this amplified perception state that every player craves and by the concept of the élite, IMPATIA created UNOOTTO, a rare beauty Poker Table conceived for A-Game.

The features of a professional gaming Casino table, reworked by the designer, lead to the birth of a product whose classic octagonal shape is reinterpreted and developed around the diamond cut tradition: the fine leather crown, the overturned pavilion made up of crystal glass legs that give light and ethereal dimension to the structure - a synthesis of sophistication, elegance and innovation.



- ◇ Crystal glass structure
- ◇ Stainless frame and components
- ◇ Leather edge

IMPATIA



www.impatia.com



MADE IN ITALY

ITALY Busto Arsizio VA 21052 via Mentana, 7 t +39 (0331)322581